

Temperature Sensors Glass Industry

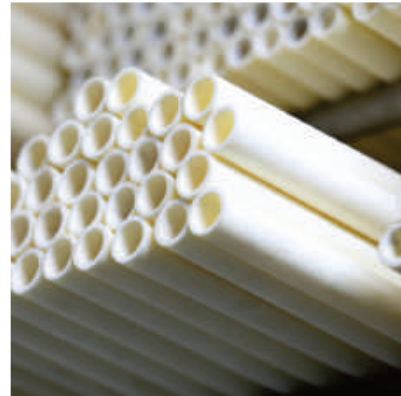

- Thermocouples
- Non Contact Pyrometers
- Glass Level Probe
- Calibration Services

- Accessories
 - ✓ Ceramic Tubes
 - ✓ Compensating Cables
 - ✓ Connectors

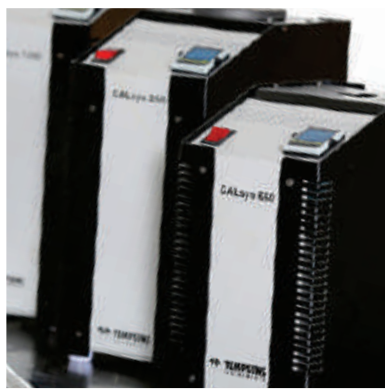
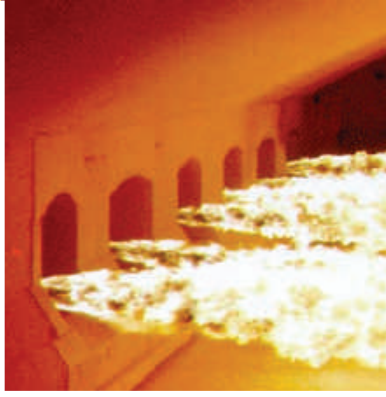

TEMPESENS

www.tempsens.com

ABOUT THE COMPANY



TEMPSENS Instruments (I) Pvt. Ltd is a part of Pyrotech group which was established by four technocrats in 1976 at Udaipur, with its first product as Thermocouples and RTDs.

Today Tempsens is one of the world's largest solution provider for thermal engineering products - ie. Temperature Sensors, Infrared Pyrometers, Heaters and Cables. The headquarters are based in India and state of art manufacturing facility in Germany.

Tempsens is an ISO 9001:2015, ISO 14001:2015, OHSAS 18001 certified company with NABL Accredited Laboratories.

The company is involved into manufacturing of Thermocouples, RTDs, Thermowells, Cables, Non contact Pyrometers, Heaters and Calibration Equipments etc. with covered area of 2,70,000 Sq. Ft.

Tempsens is proud of its technical solution, quick delivery, high technical standards and outstanding quality which have been appreciated and valued by its customers worldwide.

Tempsens exports to more than 70 countries, in all the continents.

TEMPSENS IN GLASS INDUSTRY

We at Tempsens specialize in design and manufacture of high precision temperature sensors for Glass Industries.

For more than 40 years we served major project re-builds with total Temperature Sensor Solutions which includes **Spout bowl** to **Stack Thermocouples**. Our customers have long experience of service life with our Thermocouples. We use special hardened platinum sheathing in our thimbles / claddings and all thermocouple elements used are Class 1, duly calibrated in our in house NABL accredited laboratory, which is traceable to international standards.

Type of Glass Industries Served

- Container / Bottle Glass
- TV-Panel Glass
- Tubing / Lighting Glass
- Optical & Special Glass
- Float Glass
- Tableware Glass
- Fiber Glass

Products Produced for Important Locations

- Fore-hearth Thermocouples
- Furnace Bottom Thermocouples
- Refiner Thermocouples
- Annealing Lehr Thermocouples
- Tin Bath Thermocouples
- Compensating Cables
- Pressure Probes
- Distributor Thermocouples
- Furnace Crown Thermocouples
- Spout Bowl Thermocouples
- Stack / Flue Gas Thermocouples
- Glass Level Probes
- Quick Disconnecting Connectors

FACILITIES

WELDING AND BRAZING

- Laser Welding Machines
- Programmable Micro Plasma Welding Machines
- TIG Welding Machines with Pulse Modulation And Rotary Positioner
- Induction Brazing Machines
- Resistance Welding Machines
- Brazing Sets (Oxy-Acetative)
- Deep Penetration Welding Machines

MACHINING

- CNC Turning Centers
- Turn Mill Centers
- VMC Machines
- Deep Hole Drilling Machines upto 1500mm Drilling Capacity
- Milling Centers

CABLE PLANT MACHINERY

- FEP/PFA Extrusion Lines
- PVC Extrusion Lines
- Silicon Extrusion Line
- Laying Lines
- Braiding Machines - High Speed and Regular
- PTFE Extrusion and Tape Roll Down Plant
- Metering Machines
- Spark Tester & Diameter Testers

TESTING AND CALIBRATION

- NABL Accredited Calibration Lab -196°C to 1600°C for Contact and upto 2900°C for Non Contact Sensors
- Computerized Calibration System
- Fixed Point Cells-TPW, Ga, Sn, Zn, & Al and AC Bridge for Primary Standards
- Digital Radiography Setup for Junction Integrity
- PMI Setup for Chemical Analysis of Alloys

NABL ACCREDITED CALIBRATION SERVICES



C-0321

Calibration of contact and non contact type sensors in temperature range -196°C to 2900°C

- Onsite Calibration services at Customer place
- Fixed point calibration - TPW, Ga, Sn, Zn and Al
- NABL certified calibration services In house/Onsite
- Well experienced engineers

PLATINUM SCRAP METAL RECOVERY

Precious metal thermocouples always have value - even when they have completed their service life and are no longer usable. The metal content of precious metal thermocouples can be recycled into new replacements; or monetary credit can be given for their current value; or provide the user with book credit for use at a later date. All reclamations are made on a weight basis. For the most accurate and beneficial credit, used thermocouples should be returned intact for recovery of precious metal in full at our German or Indian facilities for further processing.



LAYOUT PLAN OF TYPICAL CONTAINER GLASS FURNACE

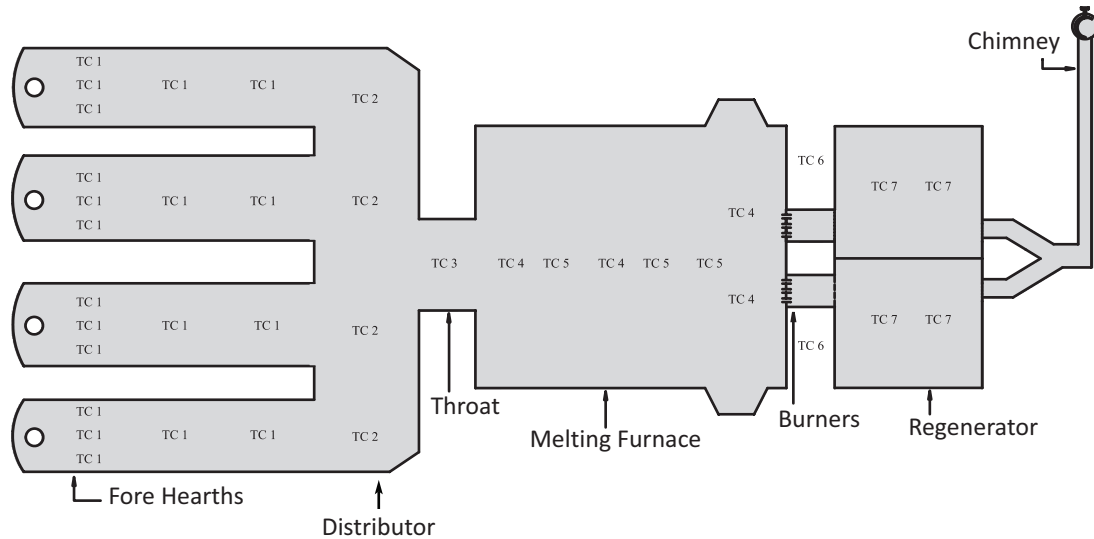

| S. No. | Description | Applicable Type of Thermocouple |
|--------|---|---------------------------------|
| TC 1 | Thermocouple for Fore Hearth | TI/GL/01, TI/GL/02, TI/GL/04 |
| TC 2 | Thermocouple for Distributor | TI/GL/01, TI/GL/02, TI/GL/04 |
| TC 3 | Thermocouple for Throat | TI/GL/01, TI/GL/02, TI/GL/04 |
| TC 4 | Thermocouple for Furnace Bottom | TI/GL/07 – A/B |
| TC 5 | Thermocouple for Furnace Crown | TI/GL/05 – A/B |
| TC 6 | Thermocouple for Regenerator checker work | TI/GL/05 – A/B |
| TC 7 | Thermocouple for Regenerator Crown | TI/GL/05 – A/B |

LAYOUT PLAN OF TYPICAL FLOAT GLASS FURNACE

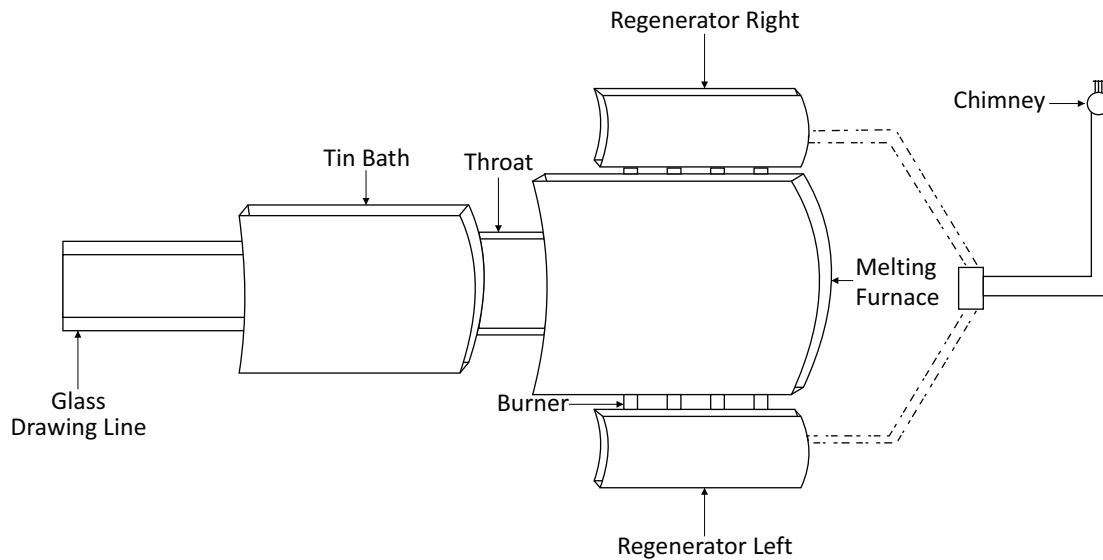

| S. No. | Description | Applicable Type of Thermocouple |
|--------|---------------------------------|---------------------------------|
| TC 1 | Thermocouple for Tin Bath | TI/GL/07–A/B |
| TC 2 | Thermocouple for Throat | TI/GL/01, TI/GL/02, TI/GL/04 |
| TC 3 | Thermocouple for Furnace Bottom | TI/GL/07 – A/B |
| TC 4 | Thermocouple for Furnace Crown | TI/GL/05 – A/B |
| TC 5 | Thermocouple for Regenerator | TI/GL/05 – A/B |

THERMOCOUPLES FOR FURNACE AND REGENERATOR CROWN

Glass Melting Furnace includes a melting chamber in which solid batch materials are heated to produce molten glass. The arch of this melting chamber is known as crown. To measure and control the temperature of furnace crown is important, because with the correct temperatures one can improve the service life of crown, as the overheating of the crown may cause of early erosion of crown refractory and on the other side if the temperatures are low, it can affect the melting efficiency and will increase the fuel consumption. The highest temperature in melting furnace is at crown. To select the right materials and assembly is quit important as the temperature at crown is even more than 1600°C. The design we recommend is with dual protection HWT (Heavy Wall Thickness) ceramic sheaths. In most of the furnaces, thermocouples are placed in block pockets, but over a period of service it may get through hole. At crown there are number of points to measure in center, right and left, the same kind of assemblies can be used for regenerator crown as well.



| Type | TI/GL/05 - A/B |
|----------------------|--|
| Measuring Range | 100 To 1600°c |
| Sensor Type | "R"/"S"/"B" |
| Protection Sheathing | Recrystallised Alumina KER-710 (C-799) Tube |
| Application | Furnace Crown , T/C Pockets, Regenerators Crown. |

| S.No. | Description |
|-------|---|
| 1. | SS/Aluminium Connection Head IP-67. |
| 2. | SS Chain. |
| 3. | ½" NPT(M) Cable Gland. |
| 4. | Holding Tube : (Inconel - 600/SS310). |
| 5. | Recry. Alumina Outer Tube :- OD X ID to be specified. |
| 6. | 2/4 Bore Recry. Alumina Insulating Tube. |
| 7. | PTRH-PT Thermocouple Element R/S/B type |
| 8. | Inner Tube suitable to outer tube. |
| 9. | Ceramic Fibre Insulated Compensating Cable |
| 10. | M/F Connector |

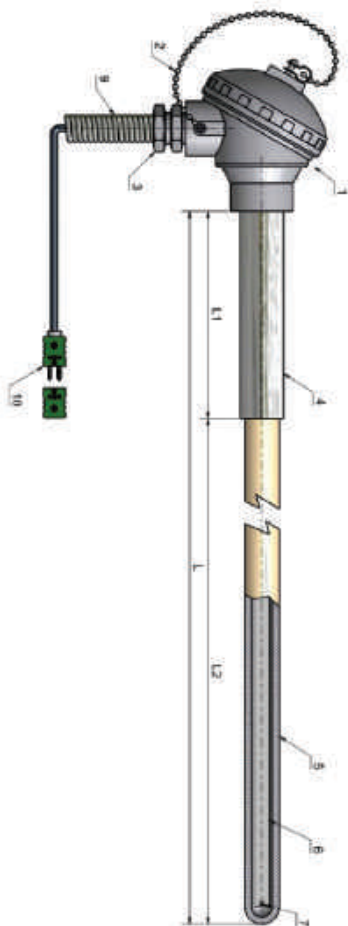

TI / GL / 05 - A
(Single Protection)

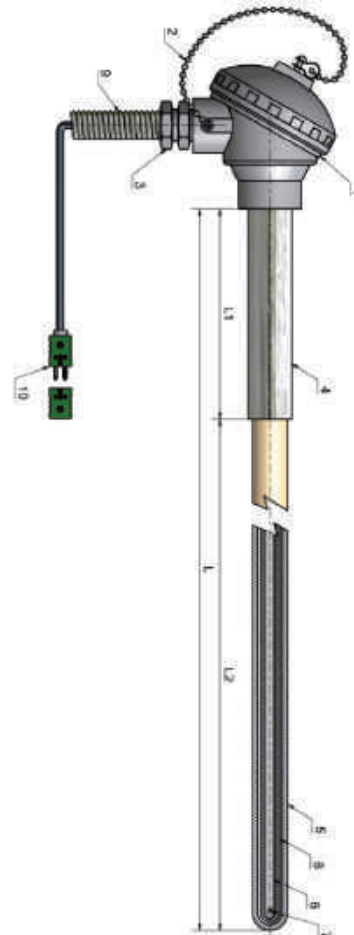

TI / GL / 05 - B
(Double Protection)

THERMOCOUPLES FOR FURNACE BOTTOM



Same as crown, to measure the correct temperatures at furnace bottom results in higher service life of bottom blocks. Bottom blocks are the costliest part of a melting tank. Bottom thermocouples are used to get efficient operation of Glass Furnace. Even 2 - 3 Degrees higher or lower temperature can affect the fuel consumption of furnace. **Tempens** Thermocouples proved the "whole campaign life" goal on many projects. On this application hole can be through to immerse a glass immersion thermocouple, which will be with hardened platinum / platinum alloy thimbles over ceramic protection tubes. If the hole is blind or provided with thermocouple pocket, the protection will be with recrystallised alumina protection sheaths.

| Type | TI/GL/07 - A/B | S.No. | Description |
|----------------------|---|-------|--|
| Measuring Range | 100 To 1600°C | 1. | SS/Aluminium Connection Head IP-67. |
| Sensor Type | "R" / "S" / "B" | 2. | SS Chain. |
| Protection Sheathing | Recrystallised Alumina KER-710 (C-799) Tube | 3. | ½" NPT(M) Cable Gland. |
| Application | Furnace Bottom, T/C Pockets, Regenerators. | 4. | Holding Tube : (Inconel - 600/SS310). |
| | | 5. | Recry. Alumina Outer Tube :- OD X ID to be specified. |
| | | 6. | 2/4 Bore Recry. Alumina Insulating Tube. |
| | | 7. | PTRH-PT Thermocouple Element R/S/B type. |
| | | 8. | Inner Tube suitable to outer tube. |
| | | 9. | Ceramic Fibre Insulated Compensating Cable 3/6 Mtrs. long with overall ceramic fiber sleeve. |
| | | 10. | Quick Release Compensated Connectors "R" / "S" / "B" Type. |
| | | 11. | Pt. Alloy thimble (in case of glass immersion) |

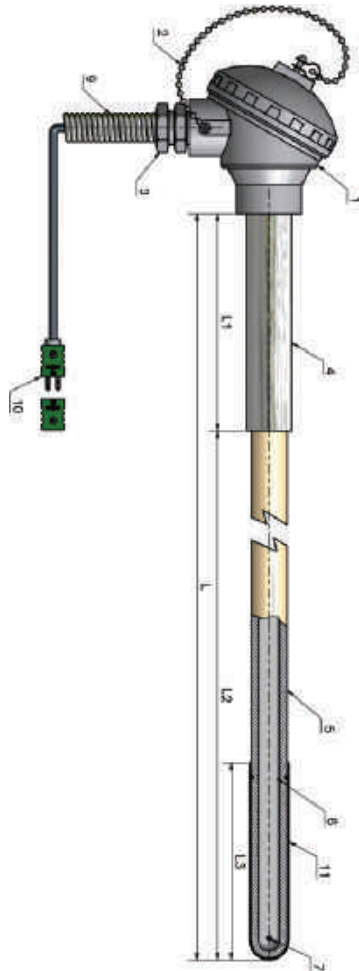

TI / GL / 07 - A
(Pt. Thimble)

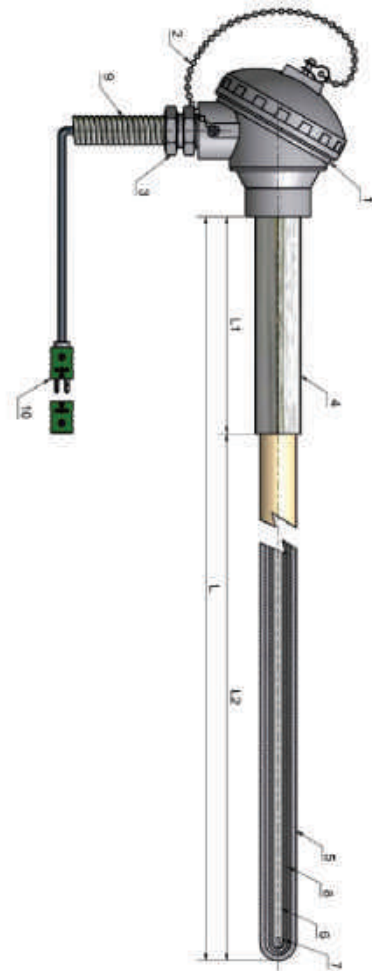

TI / GL / 07 - B
(Double Protection)

THERMOCOUPLES FOR DISTRIBUTOR AND FORE HEARTH

In distributor and fore hearths temperature measurement and control is most important. The glass fore-hearth control system includes a temperature sensing system and control system. The temperature sensing system includes an arrangement of pre-positioned temperature sensors. Simplex thimble thermocouples and tri-level / triplex thermocouples consist of an assembly of a bottom, middle and top thermocouples for sensing the vertical temperature profile of the molten glass at a fixed location. The output signals from these temperature sensors are received by controllers of the control system which then provide control signals and regulate the operation of the heat input devices and the cooling input devices. Thermocouple output and controller's calibration must be accurate, reliable and repeatable.

The Tri-Level Thermocouples designed to achieve thermal homogeneity of the glass exiting from the fore-hearth for forming, as the homogeneity will help to get the proper distribution of Gob in moulds.

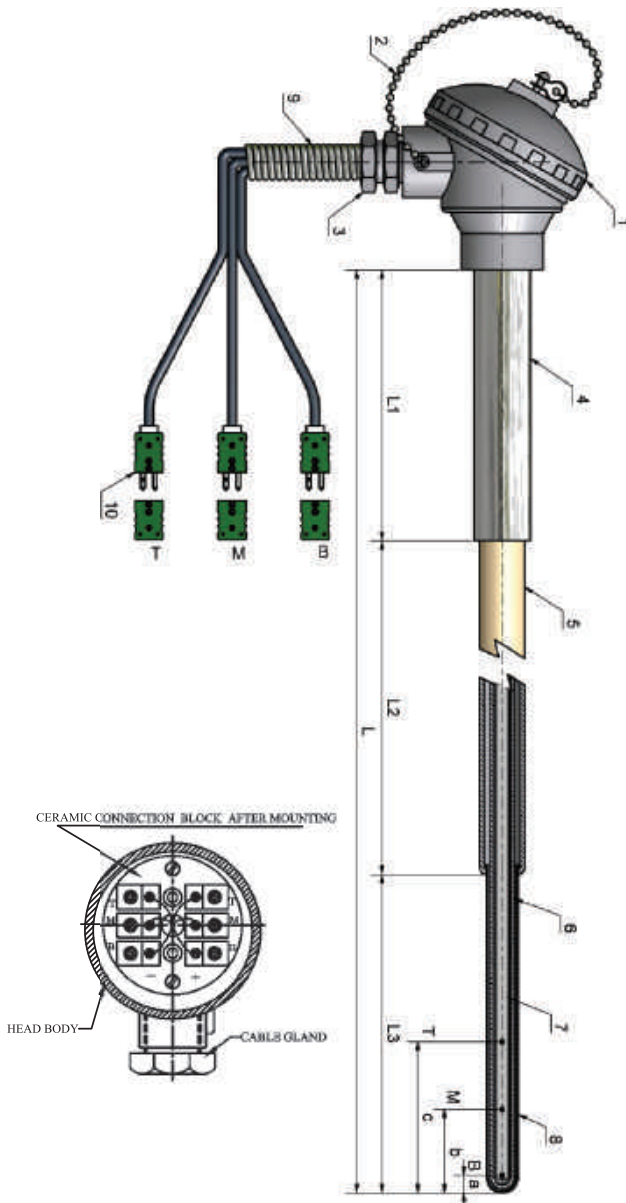
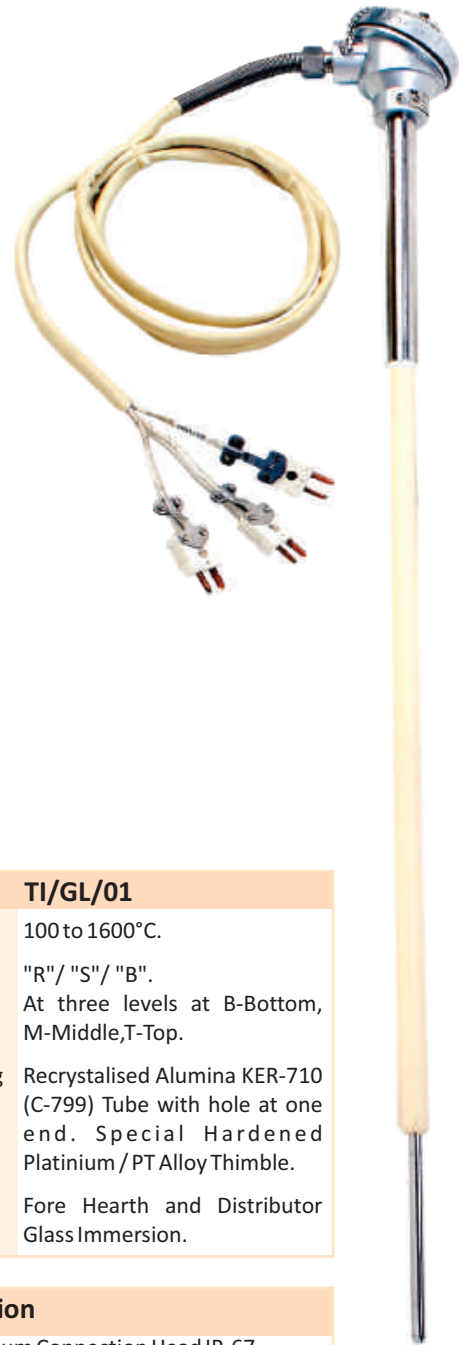

TI / GL / 01

| Type | TI/GL/01 |
|----------------------|--|
| Measuring Range | 100 to 1600°C. |
| Sensor Type | "R"/ "S"/ "B". At three levels at B-Bottom, M-Middle, T-Top. |
| Protection Sheathing | Recrystallised Alumina KER-710 (C-799) Tube with hole at one end. Special Hardened Platinum /PT Alloy Thimble. |
| Application | Fore Hearth and Distributor Glass Immersion. |

| S.No. | Description |
|-------|---|
| 1. | SS/Aluminium Connection Head IP-67. |
| 2. | SS Chain. |
| 3. | ½" NPT(M) Cable Gland. |
| 4. | Holding Tube : (Inconel - 600/SS310). |
| 5. | Recry. Alumina Tube :- OD X ID to be specified. |
| 6. | Inner Tube suitable to Outer Tube. |
| 7. | 6 Bore Recry. Alumina Insulating Tube. |
| 8. | Hardened PT/PT Alloy Thimble :- OD X THK. suitable to Outer Dimension. |
| 9. | Ceramic Fibre Insulated Compensating Cable 3/6 Mtrs. long with overall ceramic fiber sleeve. |
| 10. | Quick Release Compensated Connectors "R"/ "S"/ "B" Type. |
| ■ | a,b,c are distances from tip to bottom, middle & top sensor elements depending on the design. |

THERMOCOUPLES FOR DISTRIBUTOR AND FORE HEARTH

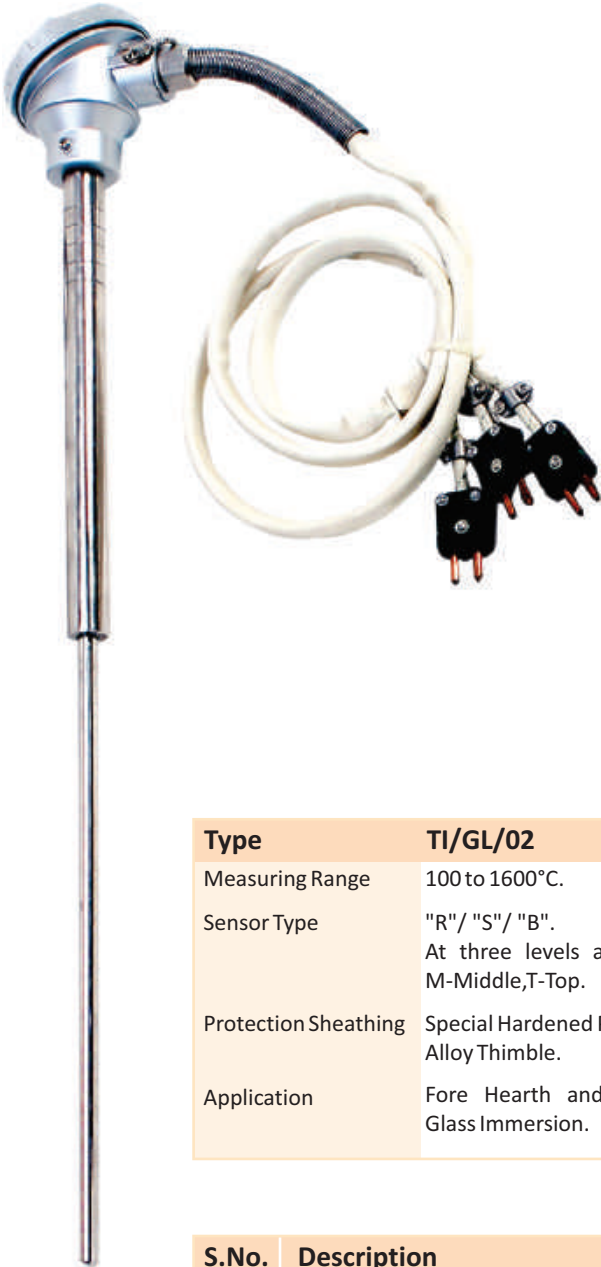

In TI/GL/01 uses small thimble length. That model is economic and commonly used worldwide, normally it gives very good service life but the only disadvantage is recovery of platinum as the ceramic tube is in flame contact and if it breaks, one can lose the whole thimble. In TI/GL/02 thimble length is long, it is from glass immersion to roofing block and thimble shall be in flame, there is no joint of ceramic tube & PT thimble in fore hearth atmosphere. It is quite popular design in heavy draw fore hearths. Where glass draw is high, customer can choose as per their requirement. All thermocouples are custom built.

| Type | TI/GL/02 |
|----------------------|---|
| Measuring Range | 100 to 1600°C. |
| Sensor Type | "R"/ "S"/ "B". At three levels at B-Bottom, M-Middle, T-Top. |
| Protection Sheathing | Special Hardened Platinum / PT Alloy Thimble. |
| Application | Fore Hearth and Distributor Glass Immersion. |

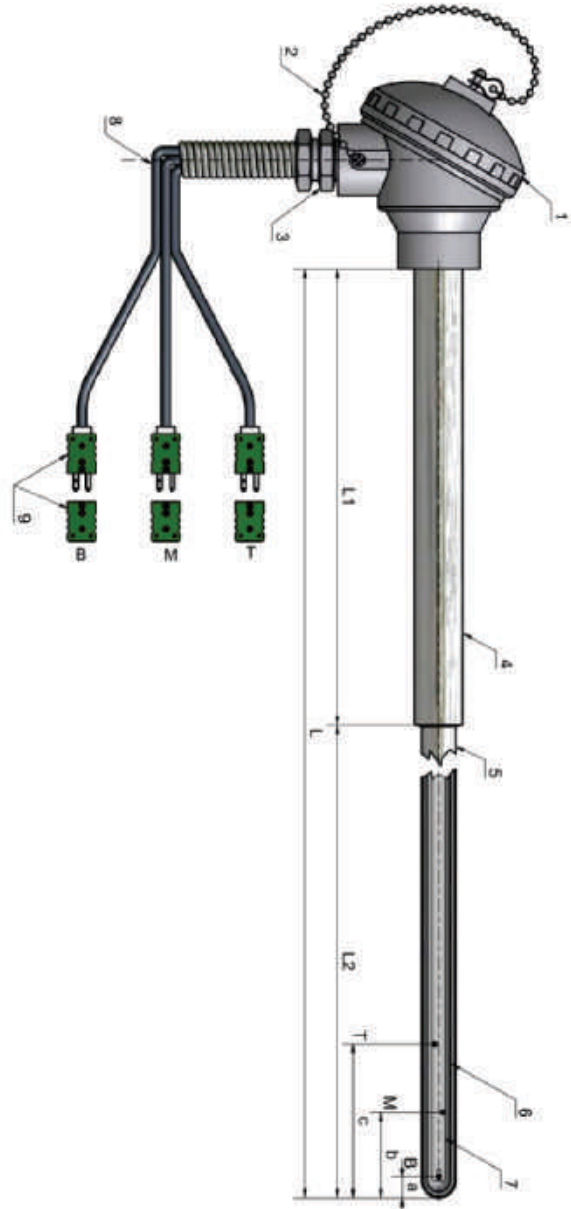

| S.No. | Description |
|-------|---|
| 1. | SS/Aluminium Connection Head IP-67. |
| 2. | SS Chain. |
| 3. | ½" NPT(M) Cable Gland. |
| 4. | Holding Tube : (Inconel - 600/SS310). |
| 5. | Hardened PT/PT Alloy Thimble :- OD X THK. suitable to Inner Dimension. |
| 6. | Recry. Alumina Tube :- OD X ID to be specified. |
| 7. | 6 Bore Recry. Alumina Insulating Tube. |
| 8. | Ceramic Fibre Insulated Compensating Cable 3/6 Mtrs. long with overall Ceramic Fiber Sleeve. |
| 9. | Quick Release compensated Connectors "R"/"S"/"B" Type. |
| ■ | a,b,c are distances from tip to bottom, middle & top sensor elements depending on the design. |

TI / GL / 02

THERMOCOUPLES FOR DISTRIBUTOR AND FORE HEARTH

In distributor and fore hearths rear and middle zone most of the glass companies use this simplex small thimble thermocouple. This is the substitute of fibre optic pyrometer. With Pyrometer customer can get only glass surface temperature but using this thermocouple, customer can get glass immersion temperatures. It is commonly used in all container glass industries. We manufacture conditioning zone trilevels and rear /middle zone simplex thermocouples from same batch element with same accuracy, our customer can get relative temperatures with high accuracy.

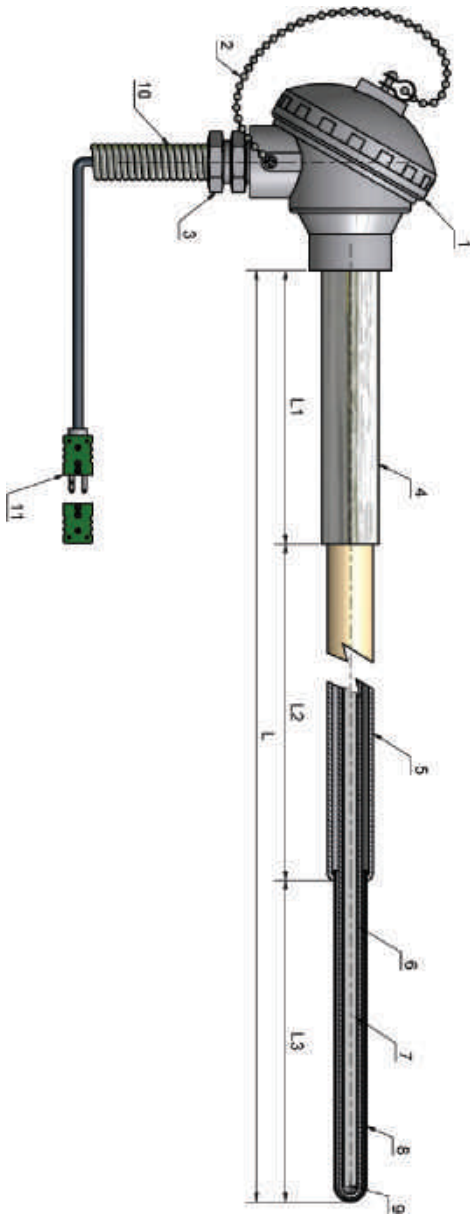

TI / GL / 04

| Type | TI/GL/04 |
|----------------------|--|
| Measuring Range | 100 to 1600°c. |
| Sensor Type | "R"/"S"/"B". At three levels at B-Bottom, M-Middle, T-Top. |
| Protection Sheathing | Recrystallised Alumina KER-710 (C-799) Tube with hole at one end. Special Hardened Platinum /PT Alloy Thimble. |
| Application | Fore Hearth and Distributor Glass Immersion. |

| S.No. | Description |
|-------|--|
| 1. | SS/Aluminium Connection Head IP-67. |
| 2. | SS Chain. |
| 3. | ½" NPT(M) Cable Gland |
| 4. | Holding Tube : (Inconel - 600/SS310) |
| 5. | Recry. Alumina Tube :- OD X ID to be specified. |
| 6. | Inner Tube suitable to Outer Tube. |
| 7. | 2 Bore Recry. Alumina Insulating Tube. |
| 8. | Hardened PT/PT Alloy Thimble :- OD X THK. suitable to Inner Tube. |
| 9. | PT-RHPT Thermocouple Element R/S/B type |
| 10. | Ceramic Fibre Insulated Compensating Cable 3/6 Mtrs. long with overall Ceramic Fiber Sleeve. |
| 11. | Quick release compensated connectors "R"/"S"/"B" Type. |



GLASS LEVEL PROBES FOR LEVEL CONTROL



Glass level probe for glass level control is made with Pt alloy probe. Inside and outside protection is with recrystallised alumina tubes, with this customer can replace old fashioned water cooled level probes. These probes are available in different type of hangers as per customer requirement. Service life is very good. All lengths & dia are available as per site needs.

| | |
|----------------------|--|
| Type | TI/GL/03 |
| Measuring Range | Glass Contact. |
| Sensor Type | Pt. or Pt. Rh alloy Electrode. |
| Protection Sheathing | Recrystallised Alumina KER-710 (C-799) Tube with hole at one end. With PT Alloy Tip for Glass Level Sensing. |
| Application | Fore Hearth & Distributor. |

| S.No. | Description |
|-------|---|
| 1. | SS/Aluminium Connection Head IP-67. |
| 2. | SS Chain. |
| 3. | ½" NPT(M) Cable Gland. |
| 4. | Holding Tube : (Inconel - 600/ SS310). |
| 5. | Recry. Alumina Outer Tube hole at Close End :- OD X ID to be specified. |
| 6. | Inner Tube suitable to Outer Tube. |
| 7. | Pt. Alloy Electrode. |

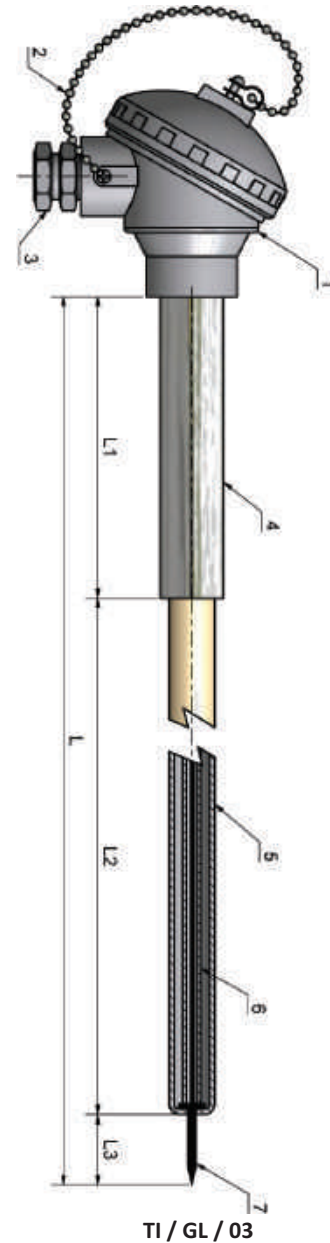

BLANK MOULD THERMOCOUPLES

To measure the temperature at Blank Mould is important ,to achieve proper gob distribution & product quality. Most of the container glass industries are using Blank Mould 'K'Type / J type Thermocouple with mineral insulating flexible high temperature cable. These thermocouples are lower in dia i.e. 1.5mm /3 mm, and as it is flexible. It can be used for different size of moulds. These thermocouples will help to get continuous monitoring of mould temperature.



SPOUT THERMOCOUPLES

In container glass industries Spout Bowl glass temperature is very important. To measure it, we designed Spout Bowl Thermocouples in noble metal with platinum thimble. It is immersed through side and user can get correct temperature of molten glass just before glass cutting. Length as per application need.

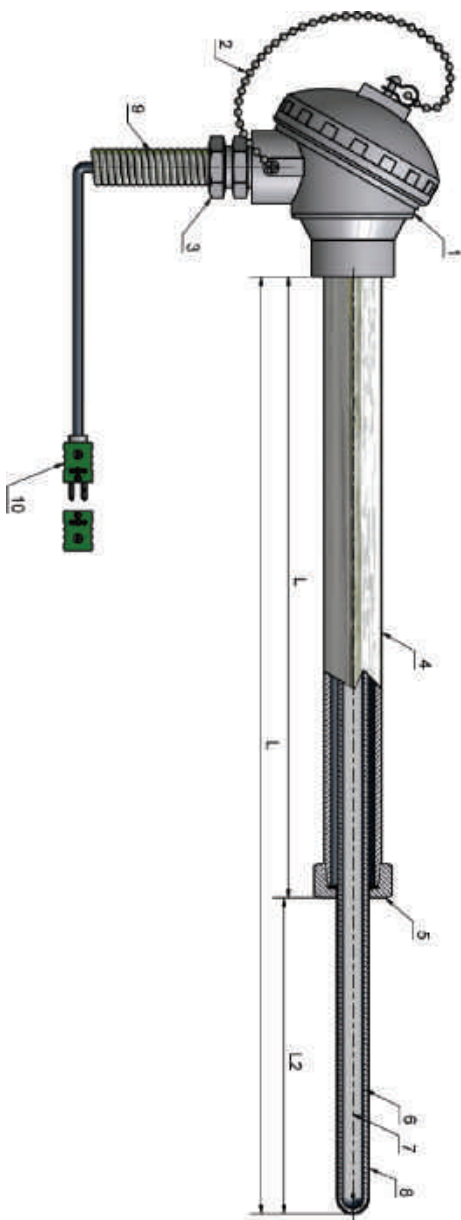

TI / GL / 06

| Type | TI/GL/06 |
|----------------------|---|
| Measuring Range | 100 to 1600°C. |
| Sensor Type | "R" / "S" / "B". |
| Protection Sheathing | Recrystallised Alumina KER-710 (C-799) Tube with hole at one end. Special Hardened Platinum / PT Alloy Thimble. |
| Application | Spout Bowl. |

| S.No. | Description |
|-------|--|
| 1. | SS/Aluminium Connection Head IP-67. |
| 2. | SS Chain. |
| 3. | ½" NPT(M) Cable Gland. |
| 4. | Holding Tube : (Inconel - 600/SS310). |
| 5. | Process Connection. |
| 6. | Recry. Alumina Outer Tube :- OD X ID to be specified. |
| 7. | Recry. Alumina Insulating Tube. |
| 8. | Hardened PT/PT Alloy Thimble :- OD X THK. suitable to Inner Dimension. |
| 9. | Ceramic Fibre Insulated Compensating Cable 3/6 Mtrs. long with overall Ceramic Fiber Sleeve. |
| 10. | Quick Release Connector "R" / "S" / "B" Type. |

COMPONENT SELECTION

Ceramic Tubes



Open Ended



Close Ended



Insulators

| | |
|------------------------|---|
| Material | : Ceramic -Alumina Tubes, Type DIN C-799, Type 610, K 80 etc. |
| Type | : One End Closed / Open Both End. |
| Standard Length | : 350, 530, 600, 650, 740, 900, 1030, 1200, 1430, 2000, 2300mm etc. |
| OD | : 5mm to 24 mm, other diameters also available on request. |

CeramTec
Germany

| Properties | Recrystallised Alumina Tube (DIN C-799) |
|---|---|
| Al ₂ O ₃ -content | 99.7% |
| Color | Yellow/ivory |
| Specific gravity | 3.85 |
| Water absorption | 0 |
| Flexural strength | 360 |
| Max. temp. use | 1.700°C |
| Thermal conductivity | 28 |
| Temperature stability | good/satis. |
| Chemical resistivity | very good |
| Te value | 1.000 |

High Temperature Cables

Compensating and Extension cables for thermocouples J,K,T,E,N,R,S,B Types.

Wire Gauge : 14 to 36 gauge (AWG/SWG)

Conductor : Solid / Multistrand

Insulation : Single and Double Fibre Glass, Teflon, Silicon, Ceramic Fibre(Nextel), Silica Fibre, SS Braided, PVC etc.

Protection : Armored / Unarmored.

Other Cables for Signal, Control and Instrumentation are available with variety of insulations and various configurations.



WIRE INSULATION IDENTIFICATION AND APPLICATION GUIDE

| INSULATION CODE | INSULATION | APPEARANCE OF CABLE | TEMP. RANGE INSULATION | ABRASION RESISTANCE | FLEXIBILITY | WATER SUBMERSION | RESISTANCE TO: | |
|-----------------|-----------------------------|---------------------|------------------------|---------------------|-------------|------------------|----------------|-----------|
| | | | | | | | FLAME | HUMIDITY |
| P | Polyvinyl Chloride (PVC) | | -40 to 105°C | GOOD | EXCELLENT | GOOD | GOOD | GOOD |
| EF | FEP | | -200 to 200°C | EXCELLENT | GOOD | EXCELLENT | EXCELLENT | EXCELLENT |
| S | Silicon | | -40 to 200°C | GOOD | GOOD | EXCELLENT | GOOD | EXCELLENT |
| T | PTFE | | -267 to 260°C | EXCELLENT | GOOD | EXCELLENT | EXCELLENT | EXCELLENT |
| PF | PFA | | -260 to 260°C | EXCELLENT | GOOD | EXCELLENT | EXCELLENT | EXCELLENT |
| K | Kapton | | -267 to 316°C | EXCELLENT | GOOD | GOOD | EXCELLENT | EXCELLENT |
| F | Fiber Glass | | -73 to 600°C | GOOD | GOOD | EXCELLENT | EXCELLENT | EXCELLENT |
| CF/SF | Ceramic Fiber/ Silica | | -72 to 800°C | POOR | GOOD | POOR | EXCELLENT | EXCELLENT |
| RF/NF | Refrasil/Nextel Silica yarn | | -73 to 1200°C | POOR | GOOD | POOR | EXCELLENT | FAIR |

Thermocouple Elements

Elements used in all TempSENS assemblies are made from using high precision calibrated thermocouple wires with class 1 accuracy. TempSENS ensures all thermocouples supplied in a single project with the same batch of element and with the same accuracy to avoid any temperature deviation. Measuring Junctions are made with highly skilled workmanship and each measuring junction is traceable in form of photograph in computer memory which can be retrieved even after long time in case of need. In high temperature applications, noble metal thermocouples R, S & B are the most used element world wide. Below are the technical specifications of these elements :

Type S : Pt vs. Pt 10 Rh

This combination is one of the most common and widely used noble metal thermocouple. The accuracy of S type element is excellent through out the range, this element has excellent mechanical and chemical properties. This combination is suitable for oxidizing atmosphere, but not suitable for reducing atmosphere.

Recommended temperature range

400°C to 1650°C continuously

Accuracy Level

Standard : $\pm 1.5^{\circ}\text{C}$ or $\pm 0.25\%$

Special : $\pm 0.6^{\circ}\text{C}$ or $\pm 0.1\%$

Size available: 0.30mm to 1mm diameter.

Type R : Pt vs. Pt 13 Rh

This combination is very similar to S type element with slight higher thermoelectric output (mV), all other properties and recommendations are same for S type.

Recommended temperature range

400°C to 1650°C continuously

Accuracy Level

Standard : $\pm 1.5^{\circ}\text{C}$ or $\pm 0.25\%$

Special : $\pm 0.6^{\circ}\text{C}$ or $\pm 0.1\%$

Size available: 0.30mm to 1mm diameter.

Type B : Pt 6 Rh vs. Pt 30 Rh

This combination is used for higher temperature application where S & R type elements are showing accelerated drift or physical degradation. Thermoelectric output of B type is lower than other two combinations.

Recommended temperature range

400°C to 1750°C continuously

Accuracy Level

Standard : $\pm 0.5\%$

Special : though special class is not available but higher accuracy are available on request.

Size available: 0.30mm to 1mm diameter.

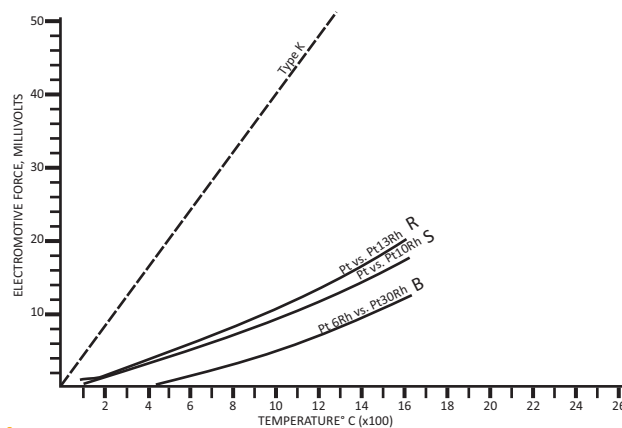

Thermocouples Junction

The photograph shown is right kind of measuring junction. The melting of both legs to be proper and equal to avoid premature opening of junction. During production, the photograph of each Thermocouple is kept as record for future reference.

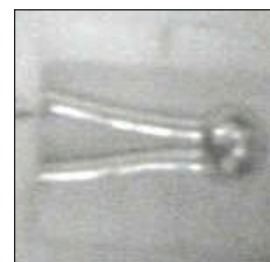

Precious Metal Thimbles / Cladding

In all Glass Immersion Thermocouples we use special hardened platinum alloys. The stress rupture strength of these hardened material is even better than Pt-10%Rh alloy, this can be checked with below table :-

| | Density g/cm ³ | Melting Point or solidus Temperature °C | Vickers hardness | Stress repture strength (100 h / 1400°C) N/mm ² | (100h / 1600°C) N/mm ² |
|--------------------|------------------------------|---|---------------------|--|---|
| Pt | 21.4 | 1772 | 45 | < 1 | - |
| Pt-10Rh | 19.9 | 1840 | 95 | 5 | 2.8 |
| Pt (Hardened) | 21.3 | 1772 | 72 | 25 | - |
| Pt-5Au (Hardened) | 21.3 | 1675 | 115 | 5 | - |
| Pt-10Rh (Hardened) | 19.9 | 1840 | 150 | 40 | 17.0 |

With Hardened Platinum we have succeeded in supplying a new class of materials with greatly improved high temperature properties and corrosion resistance compared with pure platinum and platinum alloys.

The dispersoids not only cause a considerable alternation in the crystallization properties, but also at high temperatures prevent the loss of the additional hardness which is achieved when forming the material to finished product state. In this way, equipment which is made of Hardened Platinum can be produced from less material and can be employed at temperatures approaching the melting point of platinum without the need for supporting components.

Due to modified grain structure, Hardened Platinum materials are considerably more resistant to grain boundary corrosion than traditional materials.

In Glass industry, equipment is normally exposed simultaneously to several forms of loading ,e.g. high temperature exposure, mechanical stress, corrosive attack etc. Problems which have previously arisen in the choice of equipment can be now solved by the use of dispersion strengthened materials.

Holding Tubes

We have selection of holding tubes in different metals and sizes depending on application and temperatures, Most used material in holding tubes are Inconel-600 / 800, SS310 & SS316. Diameter of holding tube will depend on the size of outer protection tube.

Looking to the importance of all above critical components we are extremely careful for the quality of all components as it is really important to ensure stable & repeatable results for our supplied thermocouples.

NON CONTACT RADIATION PYROMETERS (FIBRE OPTICS)

Fibre Optics Pyrometers

Tempsens Fibre Optics Pyrometers are specially designed digital pyrometer for glass industry application which provide high performance with low maintenance. Especially designed for Glass furnace, fore hearth, Feeder and working end. The rugged fibre optic cable is designed to withstand high ambient temperature without water cooling. Emissivity, sub range or response time and peak picker can be preset ex works or adjusted through software.



AST 450 G-2

| Type | Fibre Optics Pyrometers |
|-------------------|--|
| Temperature Range | 600 1800°C (User Programmable) |
| Features | Two wire designed High Accuracy Fast Response Time Suitable for High ambient Temperature upto 250°C Rugged Stainless Steel Housing |
| Application | Furnace Crown, Forehearth /Feeder, Furnace Side wall, Working End, Molten Glass Temperature Measurement. |



| Specification | |
|------------------|--|
| Emissivity | 0.05...1.0 Adjustable Via DIP switches & Through service interface |
| Spectral | 1 µm |
| Field of View | 100 : 1 (Approx.) Min. Spot 11mm |
| Response | 250ms Adjustable upto 10s |
| Analog Output | 4.....20mA |
| Digital | USB 2.0 |
| Protection Class | IP 65 |
| Power | 24VDC |
| Accuracy | ±0.3% of measured value or ±3°C which ever is greater |



ONLINE PYROMETERS (GLASS SURFACE & GOB)

Glass Surface Pyrometer

The measurement of the surface temperature of glass is very important in many production processes connected with the heating or cooling of glass such as in Toughening of glass, test of thermal resistance of glassware, monitoring the temperature of strip drawn from the furnace, Float Glass Production, Bottle Temperature, Bulb Shell and Tube temperature.

It is simple to use and it provides highly accurate digital signal .It is equipped with a digital interface, enabling temperature indication and storage on a PC. The temperature sub range can be configured and the instrument parameters can be adjusted remotely.



AST AL514

| Type | Glass Surface | Specification | |
|-------------------|---|----------------|------------------------------|
| Temperature Range | 300...1400°C | Emissivity | 0.1 1.0 |
| Features | Four-wire design High accuracy due to digital linearisation of the output Adjustable exposure time Compact housing | Spectral Range | 5.14 µm |
| Application | Temperature Measurement of Glass Surfaces in Float Glass | Field of View | 50:1 |
| | | Response Time | 10msec to 10 sec. adjustable |
| | | Analog Output | 4.....20 mA/0.....20mA |
| | | Digital Output | TTL Output |

Glass Gob Pyrometer

Glass gob temperature measurements can only be made using non-contact thermometers. The pyrometers needed for this application must be fast-acting due to the high cycle frequency and must be capable of measuring the temperature inside the gob. This is necessary because the surface temperature of the glass is very easily influenced by ambient conditions. It is usual to store the maximum measured temperature (peak picking) for subsequent processing. Two colour techniques make the instrument work accurately in contaminated atmosphere



AST A450C

| Type | Glass Gob | Specification | |
|-------------------|---|---------------------------|---|
| Temperature Range | 600...1600°C 800...2500°C | Emissivity Slope ε1/ε2 | 0.75.....1.25 slope Adjustable |
| Features | Two Colour Design (Switchable to mono mode) High accuracy Adjustable Measuring ranges Max. Value Storage Very small spot sizes Laser targeting light or View Finder Analog output and Digital interface | | 0.7 to 1.15 µm |
| Application | Temperature Measurement of Glass Gob | Response Time | 20 msec. adjustable upto 10sec. |
| | | Analog Output | 0... 20 mA, 4 ...20mA 0 to 10V (user selectable) |
| | | Digital Output | RS 232/RS 485 Switchable, Bluetooth |
| | | Sighting | Laser Targeting Light or View Finder |

PORTABLE GLASS PYROMETERS

Portable Glass Mould Thermometer(P-GM+)

The PGM+ (Portable Glass Mold Thermometer) is a hand held, battery powered Non-Contact thermometer designed primarily for the measurement of mold temperatures in container glass industry.

PGM+ is equipped with OLED display, operating button and optical head.

Readings taken are stored into memory and logged with Serial number and date/time for review later. Stored temperature readings are held in memory until deleted, they are not lost when the unit is turned off or the battery is removed. It provides a powerful data logging capability with storage for up to 1000 measurements.



AST P-GM+

| Type | General Application | Specification | |
|-------------------|---|-------------------|----------------------------------|
| Temperature Range | 250 600°C | Emissivity | 0.1 1.0 Adjustable |
| Features | <ul style="list-style-type: none"> • Accurate, Fast, Easy measurement • Portable and convenient • Interchangeable on site, with probes of different lengths and bends. • Battery Indication : Low battery, charging and fully charged battery. • Adjustable Probe Rotation : 360° rotation in 18 Steps | Spectral Range | 1.6 μm |
| Application | Glass Mould Temperature Measurement | Response Time | 2 msec adjustable upto 10 sec |
| | | Digital Output | USB 2.0 |
| | | Power Requirement | 3AAA rechargeable Cell |
| | | Accuracy | ±0.3% of the measured value +1°C |

Portable Hand Held Pyrometer

P250 and P450 are specially designed portable IR pyrometer for non contact temperature measurement between 210°C to 3000°C in demanding industrial environments. The Instruments feature high accuracy.

The multi functional bright back light additional LCD graphic display panel provides an indication of status and configuration of pyrometer together with measurement mode. The measuring result is shown and can be analyzed directly on site.

Through the lens sighting gives a precise definition of the target spot and temperature data inside the view. Bluetooth connectivity allows wireless connection for data transfer.



AST P250/P450

| Type | General Application | Specification | |
|-------------------|---|--------------------|--|
| Temperature Range | 210 3000°C | Emissivity | 0.1 1.0 Adjustable |
| Features | <ul style="list-style-type: none"> Fast response time Through the lenses view finder sighting Focusable precision optics Temperature display in view finder & on the multifunction display Standard Bluetooth & USB Connectivity Small Spot Size Large data storage Numeric & Graphical LCD Display | Spectral Range | 1.0μm, 1.6 μm |
| Application | Glass Mould & Molten Glass Temperature Measurement | Response Time | 5msec. in numeric mode 10msec. in graphical mode 10msec. (when data storage is 'ON') |
| | | Sighting | Through lens view finder |
| | | Measuring function | NORMAL, MAX, AVG |
| | | Data Storage | 4000 values |
| | | Serial Interface | USB 2.0 |

INSTALLATION RECOMMENDATIONS

The following installation recommendations are based on the long experience available with tempens. However, each furnace must be considered independently and selectively to determine if these recommendations are appropriate. Tempens is always pleased to provide technical support to our customers about the installation and thermocouple design .

Method of Good Installation :

Connection Head should be 6" to 12" above roofing, protection sheath should be properly packed with high temperature insulation to avoid heat.

Preheating : Tempens recommend a preheating of thermocouple at a temperature of 200°C - 300°C for atleast 12 hrs & then gradual immersion of thermocouple can be done.

Furnace crown immersion thermocouple

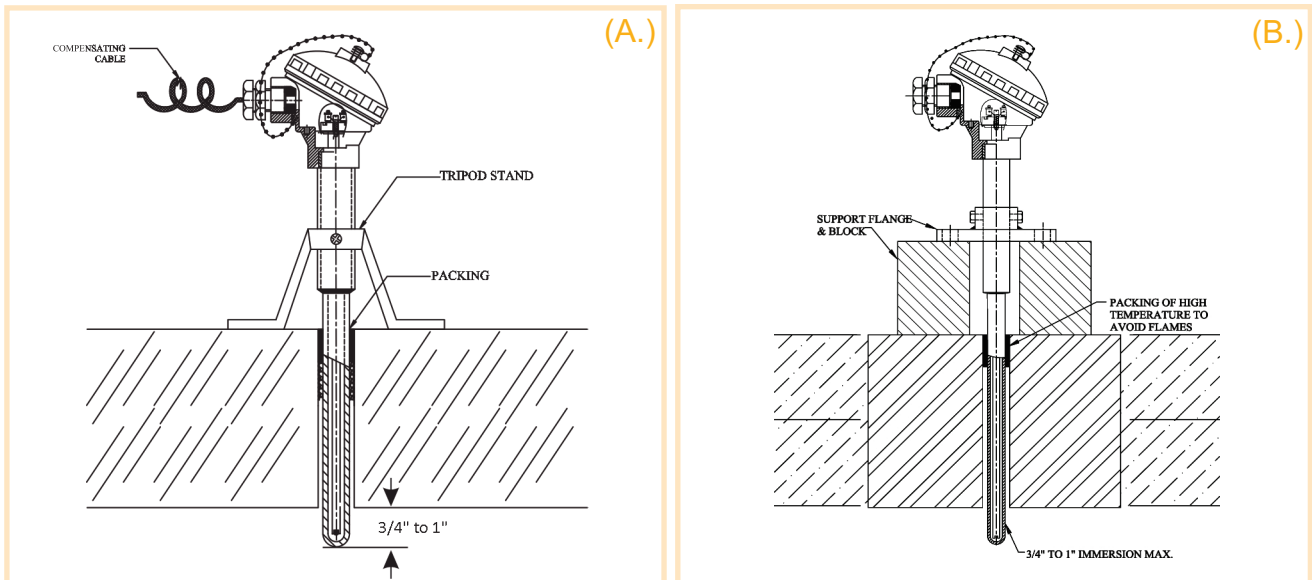

Non Immersion or In Block (Blind) Installation

On Furnace Crown, Regenerator Crown & Many Glass Industries uses non immersion or Blind Thermocouples. This installation recommendation is ideal for all non immersion designs.

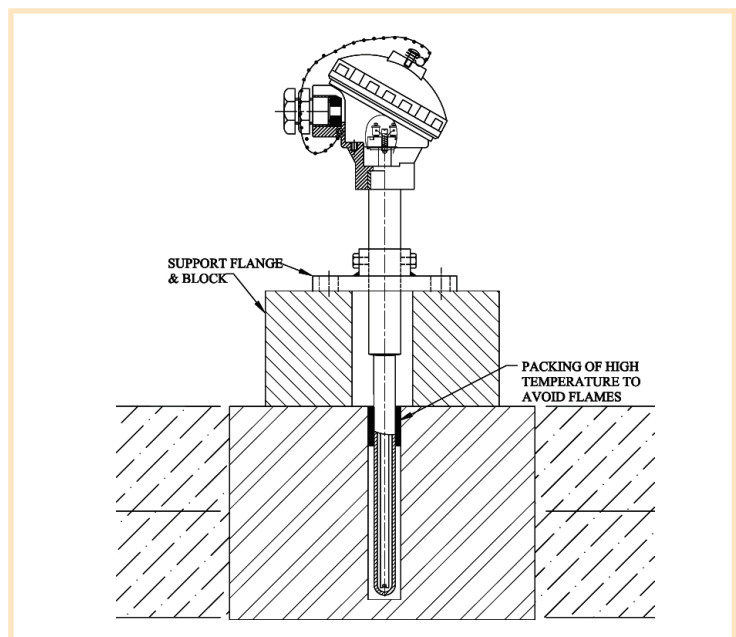

INSTALLATION RECOMMENDATIONS

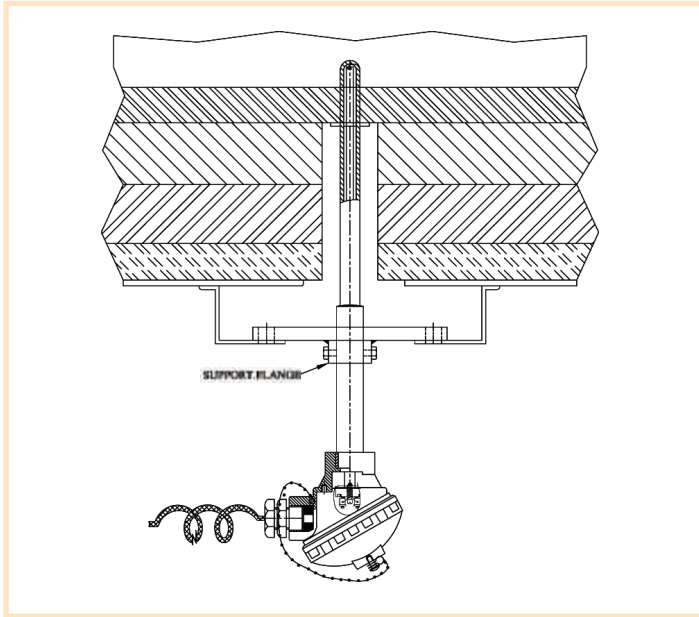

Furnace Bottom Immersion Thermocouple

A common approach to immerse a thermocouple through a layered bottom. Shown is the partially thimbled thermocouple, with a flanged installation. Cooling air may be required to insure glass seal off.

Direct Immersion

Full length thimble designs can extend up to 4 inches beyond the bottom of the block. The hole diameter should be kept to a minimum (15 mm) and counterbored only if shifting, tilting, or shear cracking are anticipated. By installing blocks with one or two additional blind holes in them, hot drilling and insertion of replacement thermocouples, bubbler tubes, etc., can be easily accommodated.

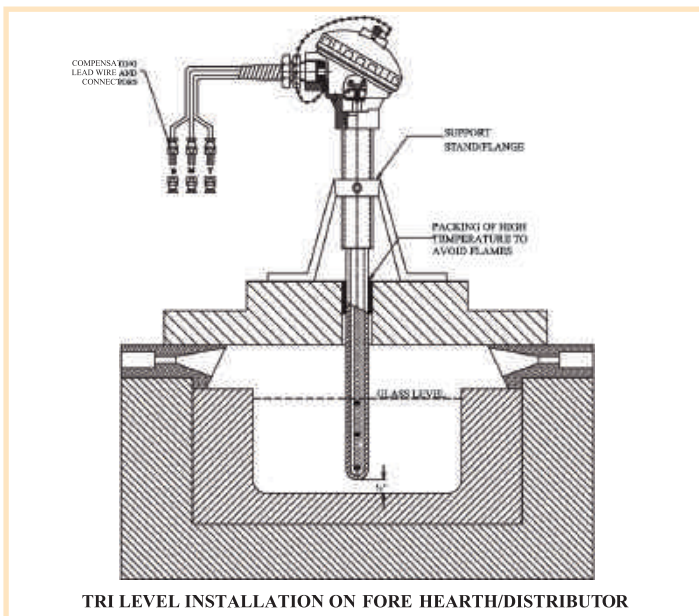
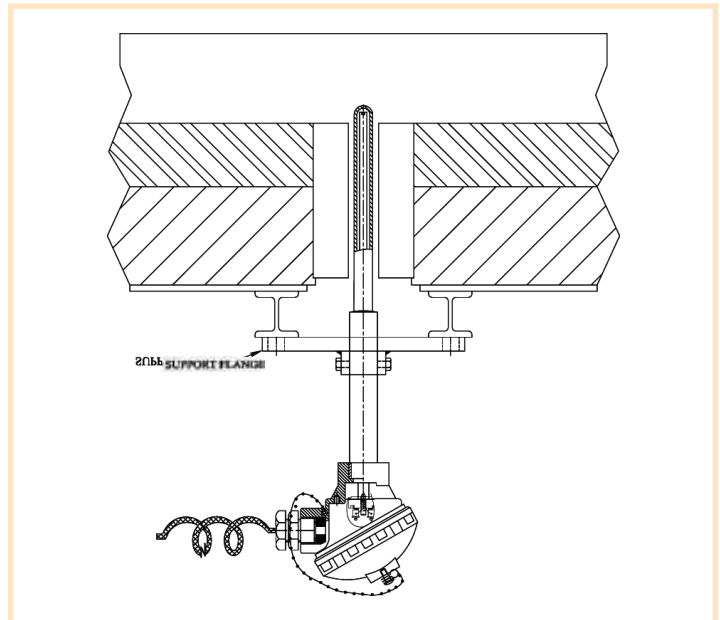

Method of Tri Level Installation on Fore Hearth / Distributor

Connection Head should be 6" to 12" above roofing, protection sheath should be properly packed with high temperature insulation to avoid heat.

Thermocouple should be 1/2" above bottom block as to avoid any breakage due to thermal expansion. All three points should be in the glass depth & difference in thermocouple points to be selected as per glass depth.

THERMAL & CABLE SOLUTIONS



www.tempsens.com

INDIA

Tempens Instruments (I) Pvt. Ltd.
B-188A, Road No.5, M.I.A.,
Udaipur-313003 (Rajasthan) INDIA
Ph.: +91 9116554600
Email : info@tempsens.com

GERMANY

Tempens Instruments GmbH
Loehestrasse 37,
53773 Hennef, GERMANY
Ph. : +49 2242 8703 22,
Fax : +49 2242-8703 20,
Email : basant@tempsens.com
hmueller@tempsens.de

INDONESIA

Pt. Tempens Asia Jaya
Jl. Jembatan III Komplek F.77
No. 6C Jakarta Utara14450,
INDONESIA
Hp. : (+62) 877 8080 4433
Telp. : (+62) 21 666 04006
Fax : (+62) 21 661 6789
Email:support@tempsens-asia.com

UAE

Tempens Gulf
Saif-Zone, Sharjah, U.A.E.
Ph. : (+917) 5017701266
(+971) 528822908
Email:uae@tempsens.com
mesales@tempsens.com

